

Clarke®



OSCILLATING BOBBIN SANDER MODEL NO: COBS1

PART NO: 6462013

OPERATION & MAINTENANCE INSTRUCTIONS



ORIGINAL INSTRUCTIONS

LS0820 - ISS 4

INTRODUCTION

Thank you for purchasing this CLARKE product.

Before attempting to use this product, please read this manual thoroughly and follow the instructions carefully. In doing so you will ensure the safety of yourself and that of others around you, and you can look forward to your purchase giving you long and satisfactory service.

GUARANTEE

This product is guaranteed against faulty manufacture for a period of 12 months from the date of purchase. Please keep your receipt which will be required as proof of purchase.

This guarantee is invalid if the product is found to have been abused or tampered with in any way, or not used for the purpose for which it was intended.

Faulty goods should be returned to their place of purchase, no product can be returned to us without prior permission.

This guarantee does not effect your statutory rights.

ENVIRONMENTAL RECYCLING POLICY



Through purchase of this product, the customer is taking on the obligation to deal with the WEEE in accordance with the WEEE regulations in relation to the treatment, recycling & recovery and environmentally sound disposal of the WEEE.





In effect, this means that this product must not be disposed of with general household waste. It must be disposed of according to the laws governing Waste Electrical and Electronic Equipment (WEEE) at a recognised disposal facility.

CONTENTS

The following items should be supplied in the carton. If any parts are missing, do not operate until the missing parts are replaced. Failure to follow this instruction could result in serious injury.

1 x Bobbin Sander	
1 x 13 mm Ø Sanding Sleeve 1 x 19 mm Ø Sanding Sleeve 1 x 26 mm Ø Sanding Sleeve 1 x 38 mm Ø Sanding Sleeve 1 x 51 mm Ø Sanding Sleeve 1 x 76 mm Ø Sanding Sleeve	1 x 13 mm Ø Table Insert 1 x 19 mm Ø Table Insert 1 x 26 mm Ø Table Insert 1 x 38 mm Ø Table Insert 1 x 51 mm Ø Table Insert 1 x 76 mm Ø Table Insert
1 x 19 mm (Ø) x 115 mm Sanding Bobbin 1 x 26 mm (Ø) x 115 mm Sanding Bobbin 1 x 38 mm (Ø) x 115 mm Sanding Bobbin 1 x 51 mm (Ø) x 115 mm Sanding Bobbin 1 x 76 mm (Ø) x 115 mm Sanding Bobbin	1 x Nut 1 x 15 mm Ø Spindle Washer 1 x 21 mm Ø Spindle Washer 1 x 45.8 mm Ø Spindle Washer 1 x Spanner 1 x Support Washer

SAFETY SYMBOLS

	Read this instruction booklet carefully.		Wear ear protection.
	Wear eye protection.		Wear a dust mask that is specially designed to filter microscopic particles.

GENERAL SAFETY RULES



WARNING: READ ALL INSTRUCTIONS. FAILURE TO FOLLOW ALL INSTRUCTIONS LISTED BELOW MAY RESULT IN ELECTRIC SHOCK, FIRE AND/OR SERIOUS INJURY.

1. Keep work area clear

- Cluttered areas and benches invite injuries.

2. Consider work area environment

- Do not expose tools to rain.
- Do not use tools in damp or wet locations.
- Keep work area well lit.
- Do not use tools in the presence of flammable liquids or gases.

3. Guard against electric shock

- Avoid body contact with earthed or grounded surfaces (e.g. pipes, radiators, ranges, refrigerators).

4. Keep other persons away

- Do not let persons, especially children, not involved in the work touch the tool or the extension cord and keep them away from the work area.

5. Store idle tools

- When not in use, tools should be stored in a dry locked-up place, out of reach of children.

6. Use protective equipment

- Use safety glasses.
- Use face or dust mask if working operations create dust.

7. Do not force the tool

- It will do the job better and safer at the rate for which it was intended.

8. Use the right tool

- Do not force small tools to do the job of a heavy duty tool.
- Do not use tools for purposes not intended; for example do not use circular saws to cut tree limbs or logs.

9. Dress properly

- Do not wear loose clothing or jewellery, they can be caught in moving parts.
- Non-skid footwear is recommended when working outdoors.
- Wear protective hair covering to contain long hair.

10. Dust extraction equipment

- Ensure dust extraction equipment is used.

11. Do not abuse the cord

- Never yank the cord to disconnect it from the socket. Keep the cord away from heat, oil and sharp edges.

12. Secure the work

- Where possible use clamps or a vice to hold the work. It is safer than using your hand.

13. Do not overreach

- Keep proper footing and balance at all times.

14. Maintain tools with care

- Keep cutting tools sharp and clean for better and safer performance.
- Follow instruction for lubricating and changing accessories.
- Inspect tool cords periodically and if damaged have them repaired by an authorized service facility.
- Inspect extension cords periodically and replace if damaged.
- Keep handles dry, clean and free from oil and grease.

15. Disconnect tools

- When not in use, before servicing and when changing accessories such as blades, bits and cutters, disconnect tools from the power supply.

16. Remove adjusting keys and wrenches

- Form the habit of checking to see that keys and adjusting wrenches are removed from the tool before turning it on.

17. Avoid unintentional starting

- Ensure switch is in "off" position when plugging in.

18. Use outdoor extension leads

- When the tool is used outdoors, use only extension cords intended for outdoor use and so marked.

19. Stay alert

- Watch what you are doing, use common sense and do not operate the tool when you are tired.

20. Check damaged parts

- Before further use of tool, it should be carefully checked to determine that it will operate properly and perform its intended function.
- Check for alignment of moving parts, binding of moving parts, breakage of parts, mounting and any other conditions that may affect its operation.
- A guard or other part that is damaged should be properly repaired or replaced by an authorized service centre unless otherwise indicated in this instruction manual.
- Have defective switches replaced by an authorized service centre.
- Do not use the tool if the switch does not turn it on and off.

21. Warning

- The use of any accessory or attachment other than one recommended in this instruction manual may present a risk of personal injury.

22. Have your tool repaired by a qualified person

- This electric tool complies with the relevant safety rules. Repairs should only be carried out by qualified persons using original spare parts, otherwise this may result in considerable danger to the user.

ELECTRICAL CONNECTIONS



WARNING: READ THESE ELECTRICAL SAFETY INSTRUCTIONS THOROUGHLY BEFORE CONNECTING THE PRODUCT TO THE MAINS SUPPLY.

Connect the mains lead to a standard, 230 Volt (50Hz) electrical supply through an approved 13 amp BS 1363 plug, or a suitably fused isolator switch. If the plug has to be changed because it is not suitable for your socket, or because of damage, it must be removed and a replacement fitted, following the wiring instructions shown below. The old plug must be discarded safely, as insertion into a power socket could cause an electrical hazard.



**WARNING: THE WIRES IN THE POWER CABLE OF THIS PRODUCT ARE COLOURED IN ACCORDANCE WITH THE FOLLOWING CODE:
BLUE = NEUTRAL BROWN = LIVE**

If the colours of the wires in the power cable do not agree with the markings on the plug.

- The BLUE wire must be connected to the terminal which is marked N or coloured black.
- The BROWN wire must be connected to the terminal which is marked L or coloured red.

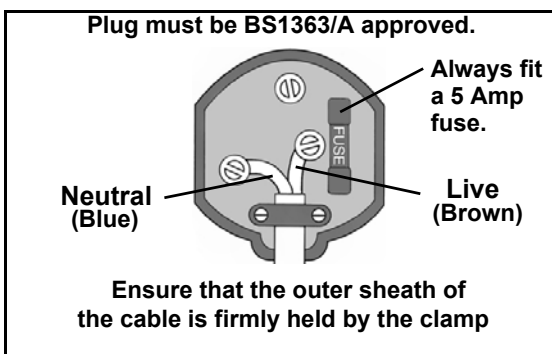

AN APPROVED RESIDUAL CURRENT DEVICE (RCD) WHICH HAS A TRIPPING CURRENT OF LESS THAN 30mA MUST BE USED.

If you are not sure, consult a qualified electrician. DO NOT try to do any repairs



This symbol indicates that this is a Class II product, and does not require an earth connection.

PARTS IDENTIFICATION

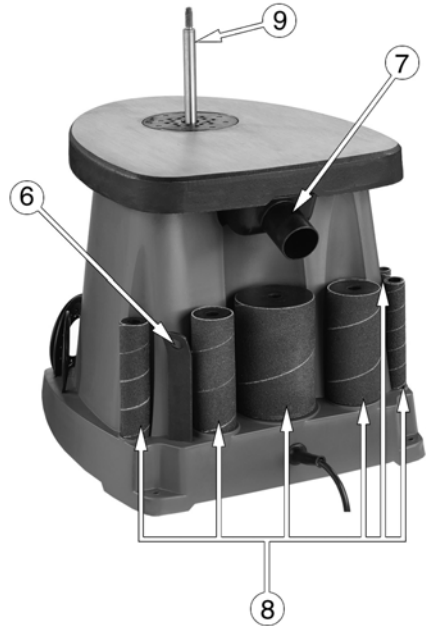

1	Table	6	Spanner
2	Bobbin	7	Dust Chute
3	Spindle Washer	8	Bobbins + Sanding Sleeves
4	Nut	9	Spindle
5	Bobbin Sander	10	Table Inserts

ASSEMBLY

FITTING THE SANDPAPER SLEEVE ONTO THE BOBBIN

1. Fit the sandpaper sleeve on to the bobbin as shown.

NOTE: The 13mm sanding sleeve does not fit onto a bobbin, it simply slides directly onto the spindle.

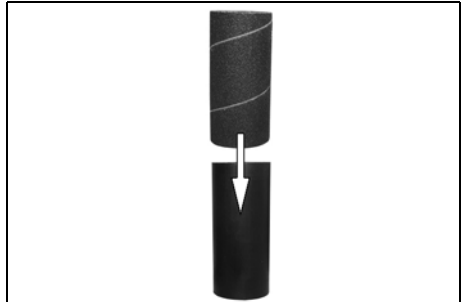

PARTS STORAGE

1. The storage slots on the front are used to store the table inserts.
2. The storage slots on the rear are used to store the bobbins/sanding sleeves and the spanner supplied.



SETUP

1. Put the support washer on the spindle.

- Grooved side must face up.



2. Slide the bobbin on to the spindle.

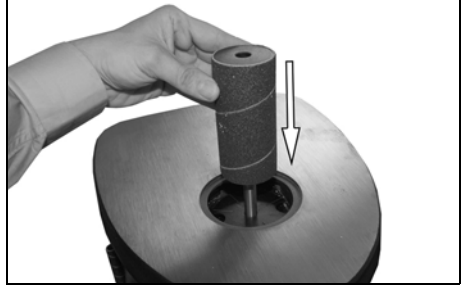

3. Secure the bobbin using the correct washer, and nut supplied.

- Use the largest washer that does not overlap the edge of the sanding sleeve.
- Tightening the nut causes the bobbin to expand slightly which prevents the sanding sleeve from sliding off of the bobbin.

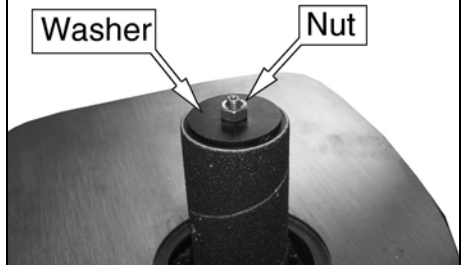

4. Put the correct table insert into place as shown and tighten up the nut on top of the bobbin.

- The table insert must be used at all times. Replacement table inserts are available from the Clarke spare parts department.

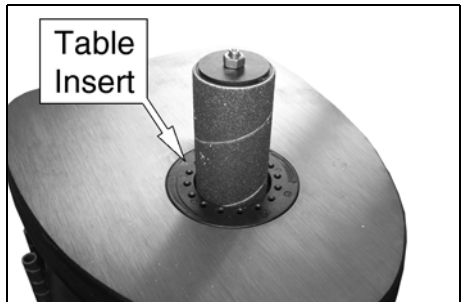

DUST COLLECTION

Connect a suitable dust collector to the dust chute.

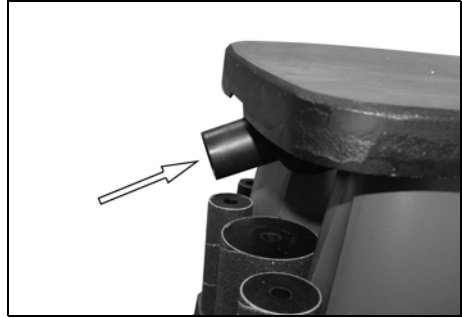

USING THE SANDER



WARNING: CONTACT WITH OR INHALATION OF DUST FROM LEAD BASED PAINTS CAN ENDANGER THE HEALTH OF THE OPERATOR AND BYSTANDERS, ALWAYS WEAR A SUITABLE DUST MASK WHEN USING THE SANDER.

SWITCH ON

Press the green ON button, and allow the machine to come up to full speed before use.

SWITCH OFF

To switch OFF, simply press the red button.

NOTE: In the event of a power failure the sander will switch off automatically. The user will need to press the green ON button again to restart.

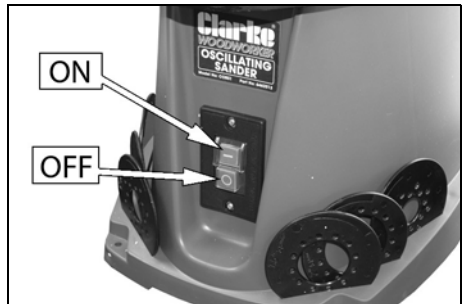

SANDING TIPS

- Do not force the sander, allow it to work at its own pace.
- Keep a firm grip on the workpiece, the sander will have a tendency to push the workpiece to the right.

MAINTENANCE



WARNING: REMOVE THE PLUG FROM THE MAINS POWER SUPPLY BEFORE CARRYING OUT ANY ADJUSTMENT, SERVICING OR MAINTENANCE

PERIODICALLY

- Keep the ventilation holes clear and free from blockages.
- Wipe the unit with a damp cloth, do not use abrasive chemicals to clean the sander.

REPLACEMENT SANDING SLEEVES

	Part Number
6pk Fine	6462580
6pk Medium	6462582
6pk Coarse	6462584

SPECIFICATIONS

Model Number	COBS1
Operating Temperature Range	0-40°C
Bobbin Speed	2000 rpm
Oscillations per min	58
Oscillation Travel	16 mm
Sanding Table Dimensions: (Length x Width)	370 x 295 mm
Table Height	330 mm
Bobbin Length	115 mm
Max Bobbin Working Height	110 mm
Dust Extraction Outlet Diameter	38 mm
Operating Voltage and Frequency	230V @ 50Hz
Input Power @ Rated Load	450W
Sanding Drum Diameters	19, 26, 38, 51, 76 mm
Grit grades	80 grit
Sound Pressure level : LpA	76 dB
Sound Power level: LWA	89 dB
Uncertainty Factor K	3 dB
Vibration aw	< 2.5 m/s ²
Dimensions (L x W x H)	400 x 350 x 450 mm
Weight	11.7 kg

The details and specifications contained herein, are correct at the time of going to print. We reserve the right to change specifications without prior notice

EXPLODED DIAGRAM

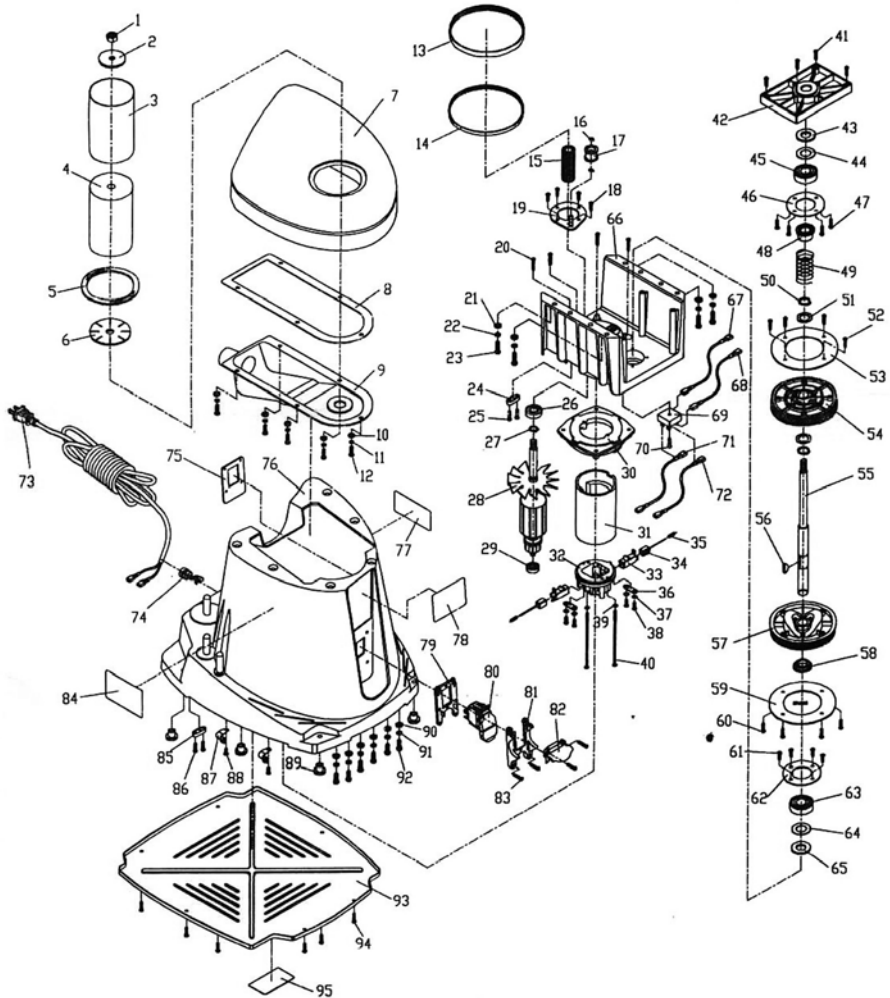

1	Hex nut 10mm	HTCOBS101	6	Lower spindle washer	HTCOBS106
2	Upper spindle washer	HTCOBS102	7	Cast iron table	HTCOBS107
3	Sander sleeve	HTCOBS103	8	Dust washer	HTCOBS108
4	Rubber spindle	HTCOBS104	9	Dust cover	HTCOBS109
5	Throat plate	HTCOBS105	10	Washer 05	HTCOBS110

11	Spring washer 05	HTCOBS111
12	Screw 5 x 12	HTCOBS112
13	Belt	HTCOBS113
14	Belt II	HTCOBS114
15	Belt wheel	HTCOBS115
16	Spring washer	HTCOBS116
17	Tension roller assembly	HTCOBS117
18	Screw 4.2 x 13	HTCOBS118
19	Orientation plate assembly	HTCOBS119
20	Screw 4.2 x 22	HTCOBS120
21	Washer 06	HTCOBS121
22	Spring washer 06	HTCOBS122
23	Screw 6 x 16	HTCOBS123
24	Cord clamp	HTCOBS124
25	Screw 4.2 x 15	HTCOBS125
26	Bearing 6001zz	HTCOBS126
27	Spring washer	HTCOBS127
28	Armature assembly	HTCOBS128
29	Bearing 608zz	HTCOBS129
30	Connection plate	HTCOBS130
31	Field assembly	HTCOBS131
32	Rear cover	HTCOBS132
33	Brush holder	HTCOBS133
34	Carbon brush	HTCOBS134
35	Brush spring	HTCOBS135
36	Cord clamp	HTCOBS136
37	Washer 04	HTCOBS137
38	Screw 4.2 x 13	HTCOBS138
39	Washer 04	HTCOBS139
40	Screw 4.2 x 110	HTCOBS140
41	Screw 4.2 x 22	HTCOBS141
42	Bearing cover	HTCOBS142
43	Felt	HTCOBS143
44	Rubber washer	HTCOBS144
45	Bearing 6203zz	HTCOBS145
46	Bearing support	HTCOBS146
47	Screw 4.2 x 15	HTCOBS147
48	Bearing sleeve	HTCOBS148
49	Spring	HTCOBS149
50	Spring washer	HTCOBS150
51	Spindle washer	HTCOBS151
52	Screw 4.2 x 13	HTCOBS152
53	Wheel plate	HTCOBS153

54	Wheel (I)	HTCOBS154
55	Spindle	HTCOBS155
56	Pin	HTCOBS156
57	Wheel (II)	HTCOBS157
58	Bearing sleeve	HTCOBS158
59	Wheel plate	HTCOBS159
60	Screw 4.2 x 13	HTCOBS160
61	Screw 4.2 x 13	HTCOBS161
62	Bearing support	HTCOBS162
63	Bearing 6203zz	HTCOBS163
64	Rubber washer	HTCOBS164
65	Felt	HTCOBS165
66	Wheel Support	HTCOBS166
67	Wire assembly (I)	HTCOBS167
68	Wire assembly (II)	HTCOBS168
69	Rectifier	HTCOBS169
70	Screw 4.2 x 19	HTCOBS170
71	Wire assembly (III)	HTCOBS171
72	Wire assembly (IV)	HTCOBS172
73	Cord	HTCOBS173
74	Cord clamp	HTCOBS174
75	Switch Orientation Plate	HTCOBS175
76	Housing base	HTCOBS176
77	N/A	HTCOBS177
78	Logo label	HTCOBS178
79	Switch orientation (I)	HTCOBS179
80	Switch	HTCOBS180
81	Switch orientation (II)	HTCOBS181
82	Switch assistant orientation	HTCOBS182
83	Screw 4 x 16	HTCOBS183
84	Warning label (I)	HTCOBS184
85	Cord clamp	HTCOBS185
86	Screw 4.2 x 15	HTCOBS186
87	Thread	HTCOBS187
88	Screw 4.2 x 10	HTCOBS188
89	Rubber foot	HTCOBS189
90	Washer 06	HTCOBS190
91	Spring washer 06	HTCOBS191
92	Screw 6 x 16	HTCOBS192
93	Bottom plate	HTCOBS193
94	Screw 4.2 x 13	HTCOBS194
95	Warning label (II)	HTCOBS195

DECLARATION OF CONFORMITY



Clarke[®]
INTERNATIONAL

Hemnall Street, Epping, Essex CM16 4LG

DECLARATION OF CONFORMITY

This is an important document and should be retained.

We hereby declare that this product(s) complies with the following directive(s):

- 2014/30/EU *Electromagnetic Compatibility Directive.*
2006/42/EC *Machinery Directive.*
2011/65/EU *Restriction of Hazardous Substances (amended by (EU) 2015/863).*

The following standards have been applied to the product(s):

- EN 62841-1:2015, EN ISO 12100:2010, EN 55014-1:2017, EN 55014-2:2015,
EN 61000-3-2:2014, EN 61000-3-3:2013.

The technical documentation required to demonstrate that the product(s) meet(s) the requirement(s) of the aforementioned directive(s) has been compiled and is available for inspection by the relevant enforcement authorities.

The CE mark was first applied in: 2010

Product Description: Oscillating Bobbin Sander
Model number(s): COBS1
Serial / batch Number: N/A
Date of Issue: 03/08/2020

Signed:

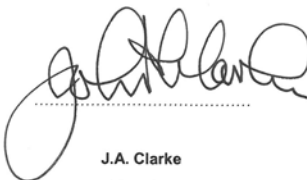

.....

J.A. Clarke
Director

A SELECTION FROM THE VAST RANGE OF

Clarke®

QUALITY PRODUCTS



AIR COMPRESSORS
From DIY to industrial, Plus air tools,
spray guns and accessories.

GENERATORS
Prime duty or emergency standby
for business, home and leisure.

POWER WASHERS
Hot and cold, electric and engine
driven - we have what you need

WELDERS
Mig, Arc, Tig and Spot.
From DIY to auto/industrial.

METALWORKING
Drills, grinders and saws for DIY
and professional use.

WOODWORKING
Saws, sanders, lathes, mortisers
and dust extraction.

HYDRAULICS
Cranes, body repair kits,
transmission jacks for all types of
workshop use.

WATER PUMPS
Submersible, electric and engine driven
for DIY, agriculture and industry.

POWER TOOLS
Angle grinders, cordless drill sets,
saws and sanders.

STARTERS/CHARGERS
All sizes for car and commercial use.



**PARTS & SERVICE:
0208 988 7400**

Parts Enquiries
Parts@clarkeinternational.com

Servicing & Technical Enquiries
Service@clarkeinternational.com

SALES: UK 01992 565333 or Export 00 44 (0)1992 565335

Clarke INTERNATIONAL Hemnall Street, Epping, Essex CM16 4LG
www.clarkeinternational.com